



3200 Series Granulators

A hydraulic tilt mechanism for the infeed hopper provides complete access to the cutting chamber and rotor for simplified maintenance, saving time and money.



Electrical controls operate both hopper tilt and screen cradle hydraulics and are wired to a zero RPM switch for safety.

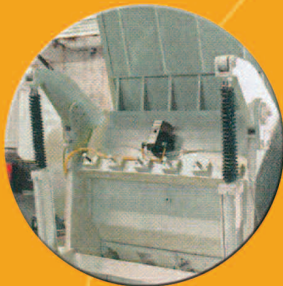

Twin heavy-duty hydraulic cylinders ensure smooth pivoting of the hopper and upper chamber.

Discharge transition chutes roll out on tracks beneath the cradle for simplified access and cleaning. Twin-pipe discharge creates high-velocity material evacuation and efficient airflow, critical for high-capacity applications.



The solid high inertia flywheel (over 4000 lbs.) creates unmatched torque and driving force at the knife tip for unstoppable cutting action.

3200 Series Granulators Offer Heavy-Duty Performance

The Cumberland 3200 Series granulators have been designed with you, the processor in mind. They cover a wide range of applications including heavy extruder purgings, blow-molded flashings, thick sheet, pipe, large blow-molded parts (automotive, appliance, furniture, profiles), X-ray films, packaging films and large-capacity post-consumer products.

Ranging in horsepower from 200 HP to 400 HP, and with throughput capacities from 6,000 to 12,000 lbs./hr, Cumberland's 3200 Series granulators offer heavy-duty design and high-capacity granulating for all your demanding applications. There is also an extensive range of features and options available in three model sizes: 32" x 42", 32" x 63" and 32" x 84".

3200 Series Granulators

Standard Features

- Hydraulic actuation system for hopper and cradle
- Slide-out pivoting discharge chute assembly
- Replaceable rotor-knife seats
- Bearings are close-fit, taper-mounted and adjustable
- Auto-Lube systems feeds a constant amount of lubricant for automated PM service

Optional Features

- Simplified access for service and maintenance
- Clean-out is quick and easy, saving valuable time
- Reduces downtime and simplifies maintenance, saving you money
- Precise control for tight-tolerance applications, critical for high-capacity bulk film
- Programmable service cycle ensures proper lubrication of bearings—no worry

Selector Guide																		
Standard Features	Infeed	Cutting Chamber	Rotor			Base	Discharge	Motor		Drive Parts	Controls	Throughput* Lbs/Hr (Approximate)	Weight Lbs/Hr (Approximate)	Dimensions				
			3-knife open offset 36° C/C (Standard)	Staggered "HOG" (Optional)	Special Options			Low profile common plate	Airveyor L/R Side (12/12/14)					1200 RPM/TEFC (Standard)	Optional	NEMA Type 12 Safety Interlocks, Hydraulic Actuation	3/8" Screen 3-Knife Open Rotor	A
3263	Tray Feed Pipe Feed	Raised Bed Knife Water-Cooled Wearplates	12-knife	30-knife	Twin High Shear™ 5-Knife Open Hard-Faced Water-Cooled	Standard	Front/Rear or Conveyor	200 HP	150-400 HP	Dual Flywheel	Motor	10,000	35,000	143-1/2	63-1/8	65-3/8	172-1/8	12
3284	Sheet Feed		18-knife											250 HP				12,000

* Rates may vary with application and are based on 3/8" diameter screen

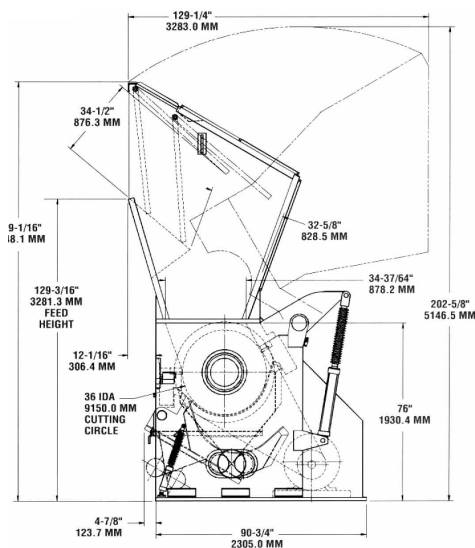
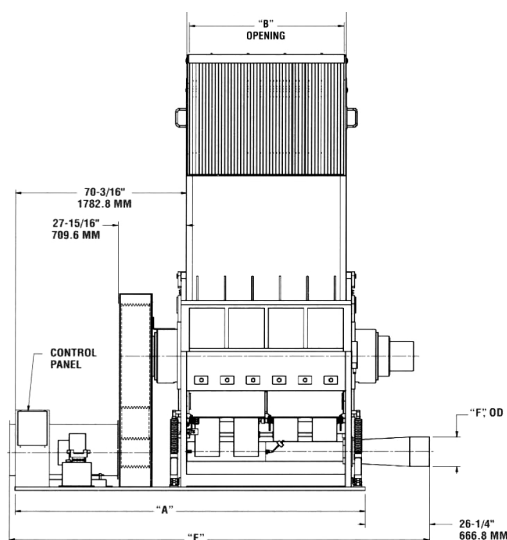

CORPORATE HEADQUARTERS

2900 S. 160th Street
New Berlin, WI 53151
TEL: (262) 641-8600
FAX: (262) 641-8653
www.cumberland-plastics.com

REGIONAL SERVICE CENTERS (800) 229-2919

ACS Tech Center
4100 Market Place
Flint, MI 48507
TEL: (810) 720-7300
FAX: (810) 720-2598

ALL DATA SUBJECT TO CHANGE WITHOUT NOTICE

©2010 Cumberland Engineering

Bulletin CG2-116.2