

# Two- and Three-Shaft Shredders

## FEATURES

Through-tempered cutters for low maintenance and long life

Contoured self-cleaning cutting chamber to reduce material buildup

Hexagonal shaft design to produce greater cutter torque

Oil bath gear lubrication for low maintenance

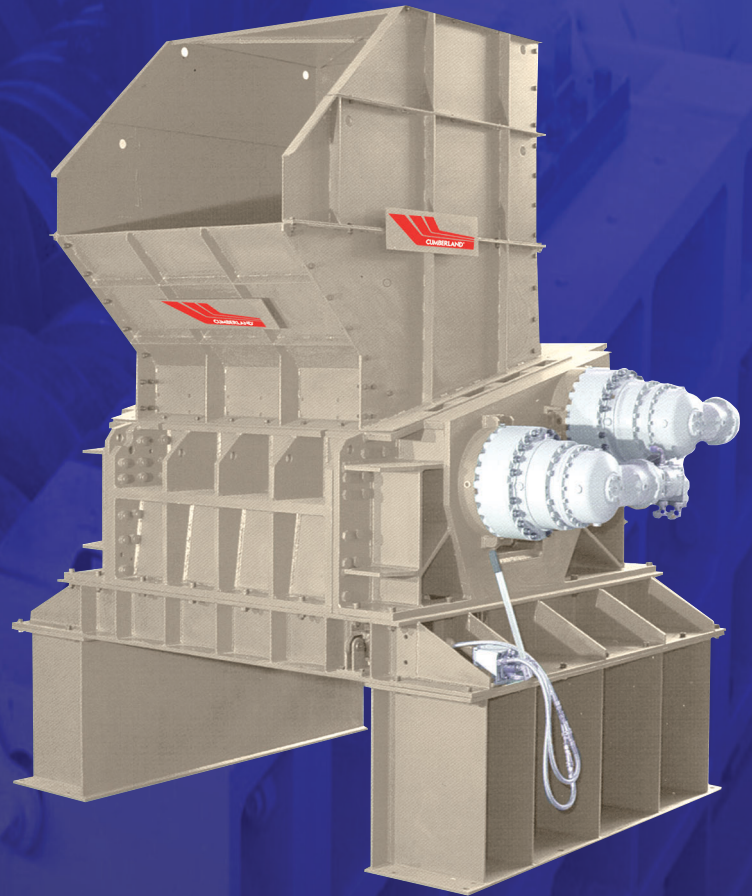

# Two- and Three-Shaft Shredders

## Two-Shaft Shredders

CHAMBER SIZE	ELECTRIC HP				HYDRAULIC HP				
	10	15	25	30	50	100	150	200	250
14" x 20"	X								
17" x 20"	X								
19" x 20"	X								
19" x 24"		X							
23" x 24"		X							
30" x 24"			X						
40" x 24"		X	X						
50" x 24"		X	X						
30" x 33"				X	X				
40" x 33"				X	X				
50" x 33"				X	X				
60" x 33"				X	X				
60" x 43"						X	X	X	X
78" x 43"						X	X	X	X
100" x 43"							X	X	X

## Three-Shaft Shredders

CHAMBER SIZE	2 Inch Screen			
	ELECTRIC HP		HYDRAULIC HP	
	30	60	80	250
19" x 24"	X			
28" x 24"	X			
30" x 30"		X	X	
40" x 30"		X	X	
60" x 43"				X
78" x 43"				X

### 2-Shaft with Discharge Screen

Size reduction for primary or secondary processing

Electronics, tires, pallets, plastics, film, C & D, medical waste, steel drums

### 3-Shaft with Discharge Screen

Size reduction with consistent particle size

Electronics, tires, pallets, plastics



#### CORPORATE HEADQUARTERS

100 Roddy Avenue  
South Attleboro, MA  
02703-7951

TEL: (508) 399-6400  
FAX: (508) 399-6653

[www.cumberland-plastics.com](http://www.cumberland-plastics.com)

Daniels Industrial Estate  
Bath Road, Stroud  
Gloucestershire GL5 5AL

England  
TEL: (44) 1453-768980  
FAX: (44) 1453-768990

ALL DATA SUBJECT TO CHANGE WITHOUT NOTICE

#### REGIONAL SERVICE CENTER (800) 229-2919

**West Coast Service Center**  
780 Miliken Ave, Suite C  
Ontario, CA 91761  
FAX: (909) 390-8143

**Central Service Center**  
101 N. Church Street  
Suite C  
Olathe, KS 66061  
FAX: (913) 780-0932

**East Coast Service Center**  
100 Roddy Ave  
South Attleboro, MA 02703  
FAX: (508) 399-6306

**ACS Tech Center**  
4100 Market Place  
Flint, MI 48507  
TEL: (810) 720-7300  
FAX: (810) 720-2598